



The ecoJoule[®] 2500 Inverter

The ecoJoule inverter is designed to provide an easy interactive interface to the electric utility for solar photovoltaic systems. The ecoJoule is designed to take the DC provided by the photovoltaic panels, and deliver the energy to the AC utility. Using patented technology, the ecoJoule maximizes the power drawn from the solar panels (this is called Maximum Power Point Tracking or MPPT). It does this while making use of a high frequency isolation transformer that helps to keep the ecoJoule compact and lightweight.

The ecoJoule inverter is designed to provide maximum system flexibility because of its low input voltage and internal transfer switch. Low input voltage inverters extract more energy from partially shaded arrays than string inverters do, thereby providing increased energy capture every day. Because of the internal transfer switch, the ecoJoule can be configured to support:

- Utility-interactive systems.
- Utility-interactive systems with battery backup. Battery charging is handled with a (separate) charge controller.
- Utility-interactive systems without battery backup. This reduces system expense and complexity by redirecting the power available from the panels directly to preselected loads.
- Grid independent systems that may be tied to the grid at some point in the future.
- System expansion in the future, through the addition of more panels or battery backup.

An LCD display on the unit allows the user to monitor the performance of the inverter.

Designed and built in the USA, the *ecoJoule* is both ecological and economic, helping you make the most of renewable energy.

The ecoJoule® Inverter



System Configurations:

Grid-Tie

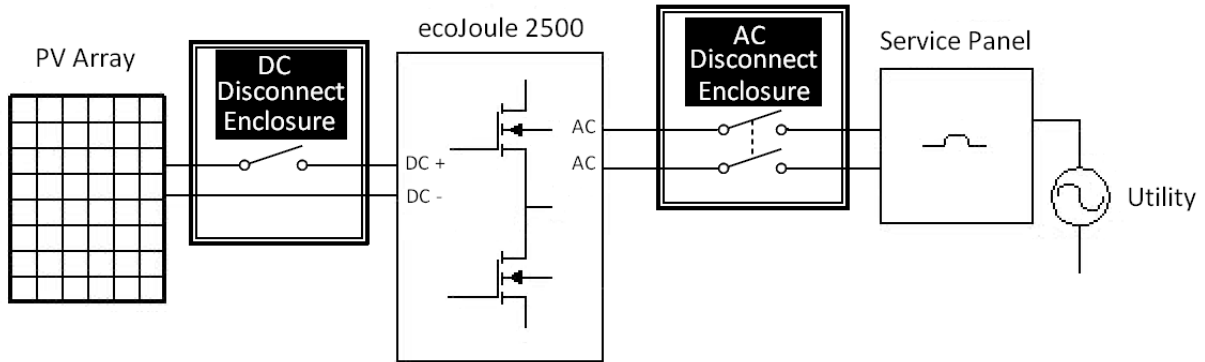

Stand-Alone with Battery Backup

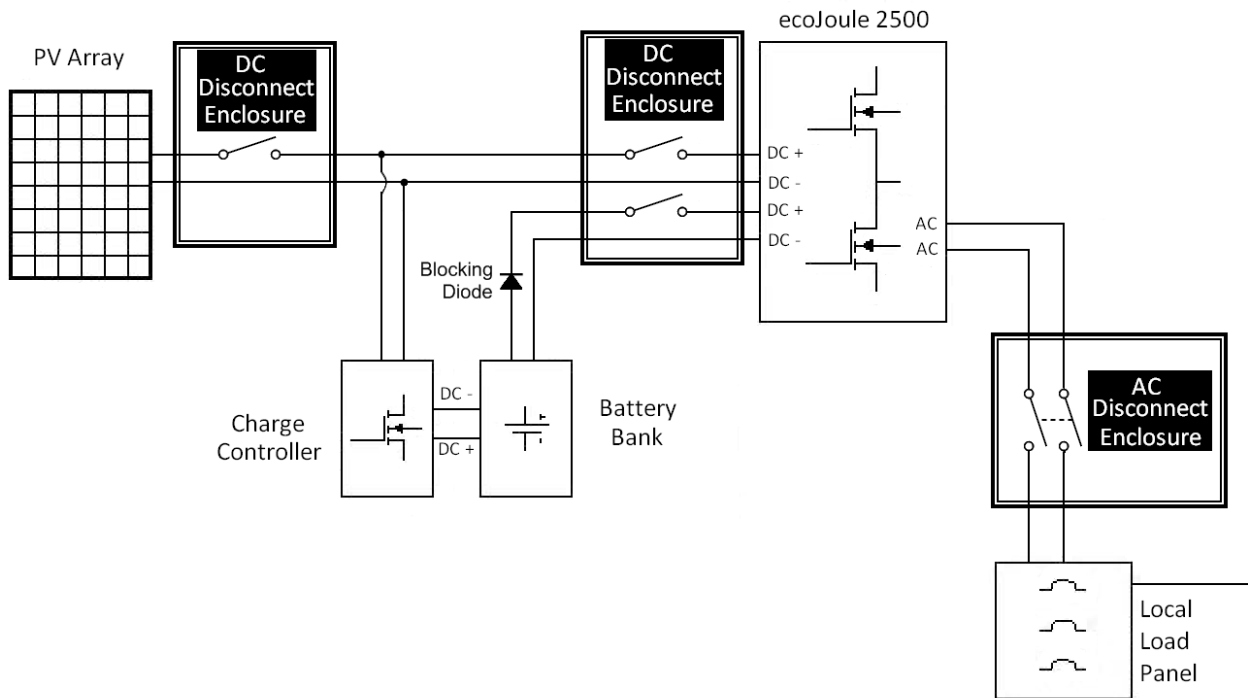

Grid-Tie with Battery Backup

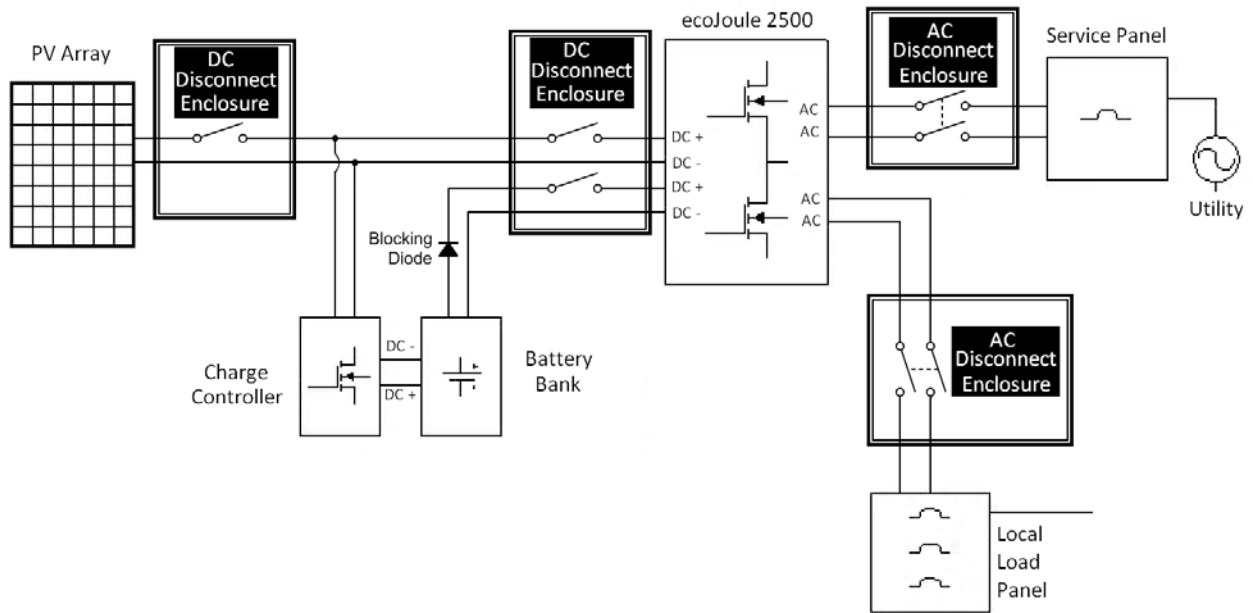

Local Load without Battery Backup

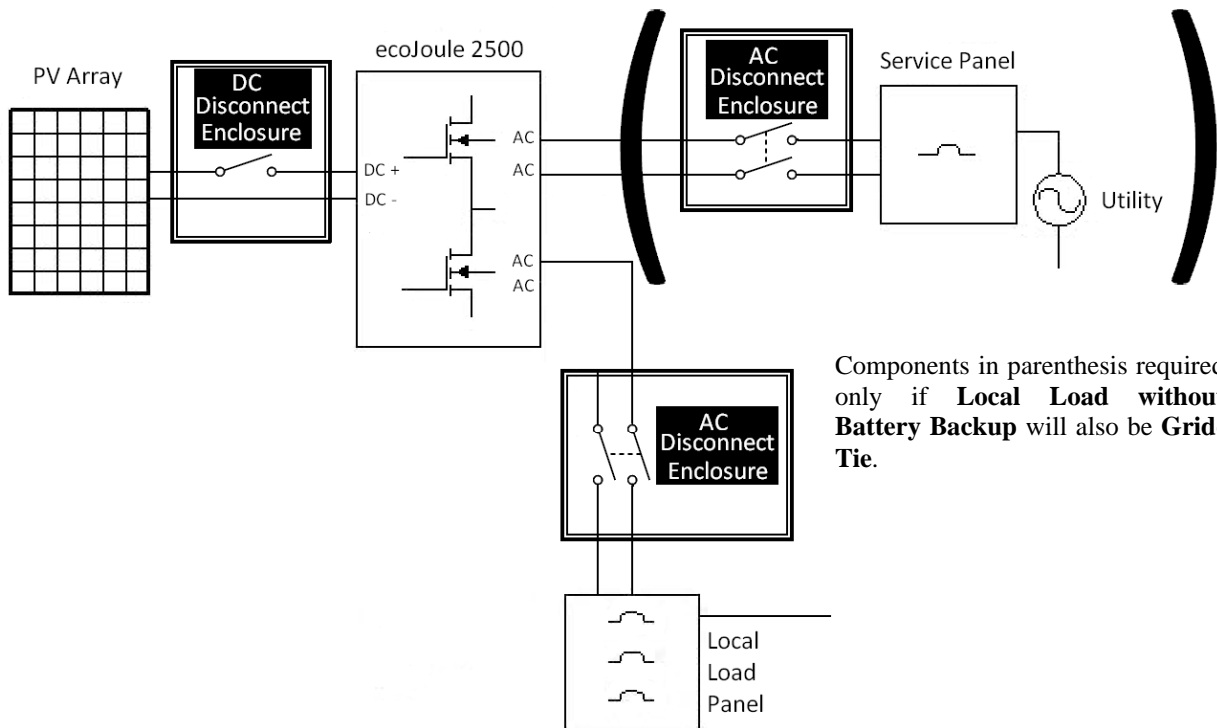

Components in parenthesis required only if **Local Load without Battery Backup** will also be **Grid-Tie**.

NOTE:

These sample configuration drawings are used to highlight the versatility of the ecoJoule 2500. Ground wires are not shown. Only a certified installer should design a solar PV system consistent with the National Electric Code and other applicable standards.

The ecoJoule 2500 inverter delivers 240 V AC to both the Service Panel and the Local Load Panel. If a different voltage is required, it is necessary to install a transformer.

ecoJoule® 2500 inverter Features:

- 2.5kW of nominal output power
- High frequency transformer isolation
- Low weight
- High efficiency
- Temperature activated cooling system
- Surge protection for both AC and DC with indication (internal LEDs)
- Integral display and keypad reporting 12 standard indicators of inverter (system) performance
- Certified to UL1741, CE
- Compliant with IEEE 1547, NEC 690, FCC
- NEMA 3R rain proof enclosure
- 10-year limited warranty

System information available from the display interface includes:

- Output power (kilowatts)
- Output AC current (amps)
- Output AC voltage (volts)
- Inverter input power (kilowatts)
- Inverter input DC current (amps)
- Inverter input DC voltage (volts)
- Inverter efficiency (%)
- Time of Day (12 Hour, AM/PM format)
- Energy (kWh) captured to date
- Energy (kWh) captured today
- Energy (kWh) captured yesterday
- Fault Information/Indicator

Inverter Output Waveforms at 2.5 kW:

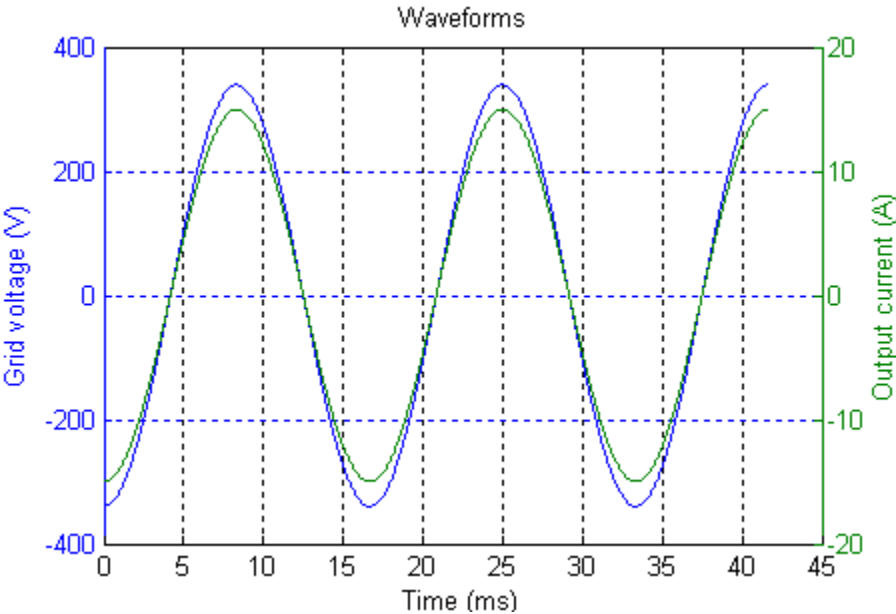

Pure Sine Wave (Sinusoid) Output